

TITLE: Data Recovery and Investigation from 8-inch Floppy Disk Media: Three Use Cases

AUTHORS: Walker Sampson (Digital Archivist, University of Colorado Boulder), Abby R. Adams (Digital Archivist, Harry Ransom Center), Austin Roche (Independent collector)

CONFERENCE: iPRES 2018 15th International Conference on Digital Preservation, Sep 2018, Boston, USA

ABSTRACT

Significant progress and guidance has been produced in data recovery for 3.5-inch and 5.25-inch floppy disks, but similar recovery steps for 8-inch floppy disks remains less documented, while also requiring more setup and configuration. The authors present three use cases centering on different collections of 8-inch floppies at the University of Colorado Boulder, the Harry Ransom Center, and an independent collection of Datapoint 1800 floppies. Strategies and methods are presented for acquiring the necessary hardware, connecting and powering the devices, and preliminary steps in data acquisition. The authors describe specific impediments to data recovery and present the gaps in producing value out of the raw data acquisition. The authors conclude that encoding and format analysis, file extraction and older machine and software emulation are all areas for further exploration in the interest of bringing older 8-inch floppy media content to researchers.

CONFERENCE THEMES ADDRESSED: Lessons learned within and across domains, Sustainable digital preservation approaches and communities

KEYWORDS: floppy disk, data recovery, digital preservation, born-digital, legacy hardware

INTRODUCTION

This report documents three use cases on recovering data on 8-inch floppy disks via a KryoFlux forensic controller. These disks are part of collections at the Special Collections, Archives & Preservation department at the University of Colorado Boulder (CU Boulder), the Harry Ransom Center at the University of Texas at Austin, as well as an independent collection of Datapoint records. This report is intended for information professionals managing born-digital collection materials on 8-inch floppy disks, and provides hardware guidance, workstation setup, descriptions of the recovery process and results therefrom, as well as troubleshooting details.

Teams and individuals at Archives New Zealand and the University of Freiburg have done excellent previous work in this area, employing programmers and experienced users of the older drive technology to help recover data from this legacy media [1]. We wish to add here to this pool of research with our investigations on recovering data, outlining how we have managed to recover, at a minimum, some of the raw data. In all three cases, raw data acquisition was achieved using only the KryoFlux and a set of 8-inch drive and adapters, all presently available. However, significant work still remains in emulation and file extraction for the both CU Boulder and the Harry Ransom Center, while the independent collection of

Datapoint disks continues to face complications relating to idiosyncrasies of that system's floppy disk formats.

BACKGROUND

Special Collections, Archives & Preservation at the University of Colorado Boulder

The University of Colorado Boulder holds a small set of thirteen 8-inch floppy disks as part of a larger floppy disk component of the Woody and Steina Vasulka collection. Woody and Steina Vasulka are experimental film and media artists, whose work often made extensive use of new digital technologies from the 1970s to the modern computing era. These disks are part of that process, and contain text documents covering the themes and mechanics of their work, along with programming instructions for the construction of 3D objects and 2D images and effects, all dating from 1976 to 1986. For example, four of the disks are labeled "grass" I-IV, which likely refers to the GRaphics Symbiosis System, a "programming language created by Tom DeFanti to script vector graphics visual animations" [2]. This is borne out by investigation of the disks revealing instruction sets and creator commentary. The disks also feature extensive physical annotations, from labeling to directory printouts folded and wrapped around the floppy disks themselves. All the 8-inch disks are soft-sectored, single-sided and single-density.

Harry Ransom Center, University of Texas at Austin

The 137 8-inch floppy disks housed at the Harry Ransom Center are a component of the born-digital materials in a large hybrid collection, the Warren Skaaren papers (FI-00123) [3]. Skaaren (1946-1990) was a screenwriter and script doctor who gained much of his success in the 1980s for rewrites of many blockbuster films, including *Top Gun*, *Batman*, and *Beetlejuice* [4]. Acquired by the Center in 1993, the collection primarily focuses on Skaaren's screenwriting work of the 1980s. Labels on disks, excluding software packages, indicate they consist largely of screenplay drafts, research notes, and limited correspondence, spanning the years 1979 to 1986. The disks are 500 kilobyte soft-sectored, single-sided, and single- or double-density. Files were created on a RadioShack TRS-80 Model II computer, which included an internal, singled-sided Shugart 500 kilobyte 8-inch floppy drive [5], in the obsolete word processing application *Scripsit* [6].

Austin Roche collection of Datapoint records

Austin Roche has held numerous engineering jobs in the computer technology sector. As the son of the Datapoint Corporation cofounder (originally Computer Terminal Corporation), Roche maintains a family connection to that company and its products. He holds a group of approximately thirty 8-inch floppy disks, collected both from former employees and purchased through eBay, that are compatible with Datapoint's 1800 personal computer system (1979-1985). The Datapoint 1800 disks employ a custom double-density, single-sided, soft-sectored track format. This custom format inhibits the creation of formatted blank disks, or the duplication of existing disks which one might use to generate working disk copies to further support restoration and documentation of a functioning 1800 system. While the Computer History Museum features a run of documents on the Datapoint 1800 [7], we are not aware of a

functioning Datapoint 1800 system. Regardless, both the 1800 system and the collection of disks can be considered quite rare. Further, the Datapoint company purchased preformatted disks and never released a system-born formatting application. The first goal of this use case is capture of each disk's raw streaming track signals for preservation, allowing further exploration for writing these raw tracks to create duplicate working disks supporting more Datapoint restoration work. While the KryoFlux hardware and software does support writing images to disk for some formats, there is no support currently for the pre-compensation timing adjustment needed to write accurate images to disk for the Datapoint 1800 machine; other methods must be investigated.

RECOVERY SETUPS

Hardware and tools used to recover data from the disks for each of these collections differs at points, but there are common devices and software in each which we want to impress here. At the Harry Ransom Center and CU Boulder, the BitCurator Environment was used, as installed directly on a system's drive. A Windows machine was also used at the Harry Ransom Center to run the *HxC* disk image program, covered in the 'Acquisition Process' section. As with the work at Archives New Zealand, we have relied on the 8-inch floppy disk power [8] and connection adapter [9] available from the D Bit developer. These two critical pieces are used in conjunction with the KryoFlux floppy disk controller for the low-level magnetic flux sampling that forms the core object of investigation.

Drive Selection

Putting aside connectors and adapters for the moment, it is immediately clear that an 8-inch drive will be needed. We have used two guiding points for the selection of our drives. Because we would be using the D Bit hardware, drives that are or are compatible with the Shugart SA800 bus were a priority, as the developer states the adapter to be designed to work with these drive types.[9] Shugart Associates (SA) were a pioneering company in the 1970s and 1980s and saw considerable success in their peripherals line. By most accounts the SA800 bus was a kind of de facto standard and saw wide use. At CU Boulder, we selected the Y-E Data YD-180 8-inch drive, specifically a "double decker" purchase (two drives physically attached, as the drive boasted a half-height design). While we were not able to discover the bus type on this model, observing a scanned manual for the drive indicated that it was designed to work with most IBM drives at the time [10].

The second criterion for drive selection is simply whatever context can be discerned on how the disks were used - the original systems and software used with the removable media by the creators. In the instance of the Vasulka disks, we have not yet been able to acquire much information on their original contexts. The disks feature a range of brands, including Scotch 3M, Nashua and Maxell, but we did not have information on the particular computers and drives used, nor the software. However, in the case of the Skaaren disks at the Ransom Center, details were acquired on their original contexts, including computer model, operating system, and software applications. Since the original computer was a TRS-80 Model II, which included an internal, singled-sided Shugart 500 8-inch floppy drive, the Shugart 851 drive would be compatible with the disks. Further to this point, the KryoFlux 'Technical Overview' webpage lists the Shugart 851 as a compatible drive [11] (the only drive listed as such, though further

discussions on drive compatibility can be found in the site's user forums), so the drive was considered a promising purchase.

Floppy Disk Drive Adapters

While the KryoFlux can accommodate both 3.5-inch and 5.25-inch drives through the connections available on the device, 8-inch drives present significant differences that require additional devices to operate them. Most apparent is that the majority of 8-inch drives feature 50-pin data connections, for which one requires both an older 50-pin ribbon with an edge connection, as well as an adapter to move this connection along to a modern system. In addition, the drives typically expect a different power input at 24V, so a power converter is needed as well. As noted earlier, both of these issues were addressed with adapter from D Bit. Importantly, these adapters provide more than simple data connections, such as adjusting the write current for floppy disk tracks above track 43, an operational feature on some 8-inch floppy disk drives.

HARDWARE	DESCRIPTION	INSTITUTION
Shugart 851 8-inch drive	<i>For basic operation of an 8-inch disk</i>	Harry Ransom Center, University of Texas at Austin Austin Roche collection of Datapoint records
Y-E Data YD-180 8-inch drive	<i>For basic operation of an 8-inch disk</i>	Special Collections, Archives & Preservation at the University of Colorado Boulder
FDADAP floppy disk adapter	<i>Adapts 8" floppy disk drives to work with the PC 3.5"/5.25" floppy disk cable pinout</i>	Harry Ransom Center, University of Texas at Austin Austin Roche collection of Datapoint records Special Collections, Archives & Preservation at the University of Colorado Boulder
FDDC DC-DC converter for 8" floppy drives	<i>DC-DC converter which boosts/negates the voltages from a PC power supply to those needed by most 8" floppy drives; DC power is used for the electronics and stepper motor</i>	Harry Ransom Center, University of Texas at Austin Austin Roche collection of Datapoint records Special Collections, Archives & Preservation at the University of Colorado Boulder

AC power cable for 8-inch drive	<i>Supplies power to the spindle drive motor</i>	Harry Ransom Center, University of Texas at Austin Special Collections, Archives & Preservation at the University of Colorado Boulder Austin Roche collection of Datapoint records
AC power adapter 12V 5V 5pin (2)	<i>Supplies power to the 3.5-inch floppy drive, FDADAP floppy disk adapter, and FDDC DC-DC converter</i>	Harry Ransom Center, University of Texas at Austin Austin Roche collection of Datapoint records
MOLEX-m to 2 x BERG-f Y-cable	<i>Power adapter for the FDADAP floppy disk adapter</i>	Harry Ransom Center, University of Texas at Austin Austin Roche collection of Datapoint records
50-pin IDC to 50-pin edge connector ribbon cable	<i>Connects the 8-inch drive to the FDADAP floppy disk adapter</i>	Harry Ransom Center, University of Texas at Austin Austin Roche collection of Datapoint records

Connecting and Powering the Drives

Practitioners already working with the Kryoflux will be familiar with connecting a floppy disk drive to the device along with attaching the Kryoflux to the host machine through USB. An 8-inch drive requires a few extra connections and power adapters to correctly run. We recommend a good amount of table space to do this, as well as an uninterruptible power supply unit to further ensure stable currents for the devices. Along with running power to the 8-inch drive itself through the FDDC converter from D Bit, the FDADAP connection will be powered as well. A Molex-to-Berg adapter may need to be acquired if one is not already at hand to connect power the FDADAP, as it does not feature a Molex connection. Finally, it should be noted that many 8-inch drives have an active motor that spins while not in use. For 5.25-inch connections, this is often an indication of an misoriented connection, but is not strictly the case for 8-inch drives. Powering requirements for the Shugart drive requires an additional step that will be covered in the ‘Acquisition Process’ section.

- Connect an AC power cable from the FDDC converter to the 8-inch drive
- Connect an AC power adapter to the FDDC converter via the Molex connection
- Connect a 50-pin floppy cable from the 8-inch drive to the FDADAP floppy disk adapter

- Connect a Berg cable to power the FDADAP floppy disk adapter
- Connect a 34-pin floppy cable from the FDADAP controller to the KryoFlux board
- Plug in and turn on all power supplies (8-inch AC power cable and 2 AC power adapters for the FDDC and FDADAP)
- Connect USB cable from KryoFlux to the host computer

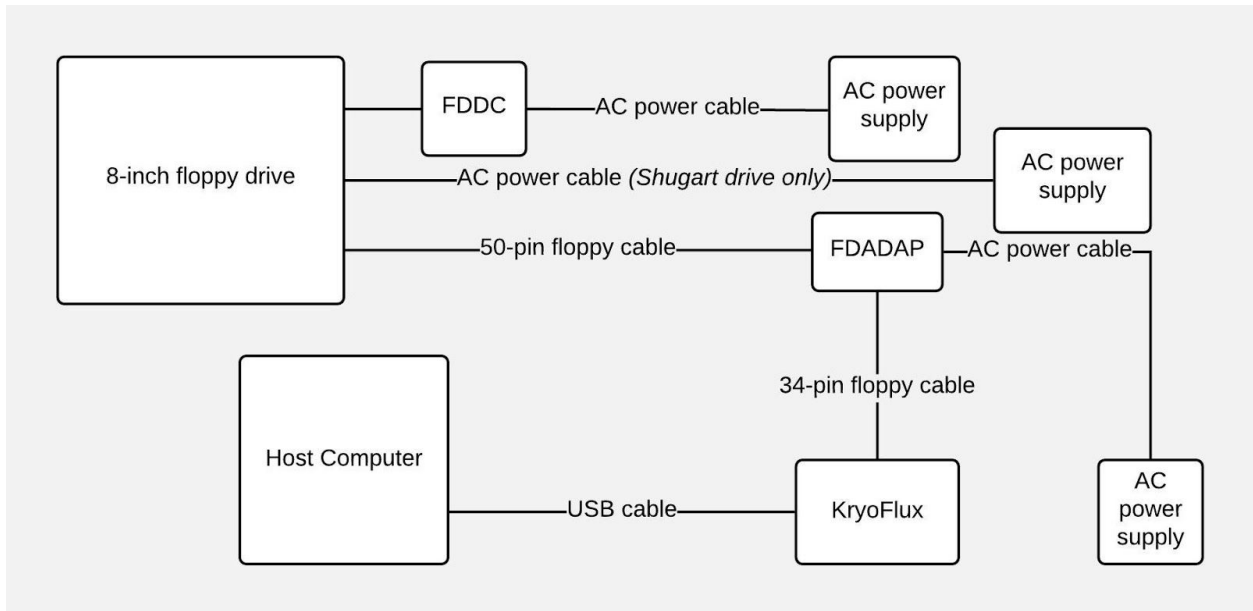

ACQUISITION PROCESS

Special Collections, Archives & Preservation at the University of Colorado Boulder

Once the Y-E Data drive was connected and calibrated by the KryoFlux, we attempted a first pass on acquiring the floppy disks' data. We set the KryoFlux disk controller to collect both the KryoFlux preservation stream files and the frequency modulation (FM) sector image profile using the multiple format option. While the outputs for this runs did provide a few positive sector reads across the images, these were not frequent enough to suggest a correct image profile. Because 8-inch disks had been used with both FM and modified frequency modulation (MFM) encodings, we then ran the MFM image profile against the collection of stream files. This similarly resulted in scattered positive sector reads. We had a uniform success however running the KryoFlux track stream files against the Digital Equipment Corporation (DEC) RX01 image profile, a 77 track, 26 sector (at 128 bytes per), single-sided format, with the exception of a single disk for which no positive sectors or reads could be derived.

Harry Ransom Center, University of Texas at Austin

Upon setting up the Shugart 851 drive recovery workstation, we realized that, unlike the Y-E Data drive in use at CU Boulder, the Shugart requires two power supplies, both DC and AC power. DC power is

used for the electronics and stepper motor, and AC power supplies power to the spindle drive motor [12]. Once the drive was calibrated, creation of preservation stream files was attempted but failed due to a faulty index sensor. The sensor was repaired and another attempt was made to recover data. During stream file creation however the following errors appeared on tracks 77 through 80: 'Error reading stream device' and 'Read operation failed'. It was determined that 8-inch floppy disks only contain 77 tracks, and adjusting the image profile in the KryoFlux host software such that the end track was 77 rather than 80 solved this issue. We also encountered a buffering error recorded in the log file due to a busy USB connection, which the DTC corrected automatically with a retry. Allocating more bandwidth to the host software may prevent the error.

Disk type could not be determined, although disks were found to have both MFM and FM encoding, but all attempts to create MFM or FM sector images from stream files with the KryoFlux host software failed, resulting in file references that do not contain any data (0 bytes). As an alternative, the floppy drive emulator tool *HxC Floppy Emulator* (v2.1.8.0) was used to read the stream data and create raw sector images, formatted with MFM and FM encoding [13]. A method could not be determined for parsing out individual files from the raw sector image due to lack of disk image extraction tools supporting a TRSDOS file system. However, hex and text editors allowed for viewing the raw text of the Scripsit 2.0 files, and some delineation between files is apparent in the data view.

Austin Roche collection of Datapoint records

During a collaborative meeting with the Harry Ransom Center Digital Archivist, when the KryoFlux and Shugart 851 workstation was first fully configured, it was observed that there was at least one, and possibly multiple, functional discrepancies that would prevent proper operation the system. The first functional issue, no rotation of the disk spindle, was solved by constructing a custom electrical cable to provide AC power to the spindle motor. Further testing of the system resulted in a software error message indicating that the KryoFlux hardware could not detect disk rotation. Using an oscilloscope it was determined that the rotation index sensor had become physically misaligned and was not producing the correct rotation electrical pulse. Repositioning the sensor receiver to its original location solved the issue and the KryoFlux workstation began operating correctly. After refinement of software options that match the drive type, the capture of raw flux level data was accomplished.

From this experience we found that the KryoFlux software and hardware does not provide the user with low level commands that are needed to control the drive which might support drive debug. For debug and calibration, Shugart issued an exerciser box internally, designed to control the drive at a low level. These are rare since they were not built in volume. In the near future we will have a hand built custom designed exerciser available, once modifications are made to be compatible with the Shugart 851 drive. When complete we will verify the compliance to Shugart OEM check points. Experience with this series of disk drives indicates a very robust design and few faults are seen in the field.

With the recording of raw flux level tracks debugged, we could refocus on the primary goal of the Datapoint 1800 collection: to record a flux level disk (single density or double density) and write a duplicate mirror disk on new media, thus allowing the original disks to be removed to safe archive.

Complications in the first step here, to create duplicate 8-inch disks, were clarified by KryoFlux in a post on their web site, which indicated that the device does not currently support write precompensation for 8-inch drives. Double data rate tracks require write precompensation to adjust to the practical limitations of real world conditions. In addition, the KryoFlux workstation will not write to the 8-inch disk configuration, instead issuing a “Write Protect” error. Work continues to find the root cause.

RESULTS

Harry Ransom Center, University of Texas at Austin

As of April 2018, KryoFlux preservation stream files were created for 106 out of 137 disks. Upon review of the raw sector images, it was found that the content closely matched the disk labels and enclosures, including notes, correspondence, and screenplay drafts related to the following films, some of them never produced: *Top Gun*, *Beetlejuice*, *The Freddie Steinmark Story*, *Of East and West*, *Lillie and Beck*, *Captive Hearts*, *The Stolen Steers*, and *Little Things*. The disks also contain some personal and business correspondence. One disk holds computer games in ADVENTURE version 8.2. A single disk appears corrupt or possibly empty.

Providing access to the parsed out files with original formatting would require creating an emulated environment for a TRS-80 Model II operating system that includes the Scripsit 2.0 word processing application. There are limited options for emulating the Model II environment, particularly due to incompatibilities in system architecture and disk format between Model I/III and Model I [14]. However, we plan to explore MAME, a multi-purpose emulation framework, and Emulation as a Service (EaaS), a scalable emulation service model, as possible solutions [15, 16].

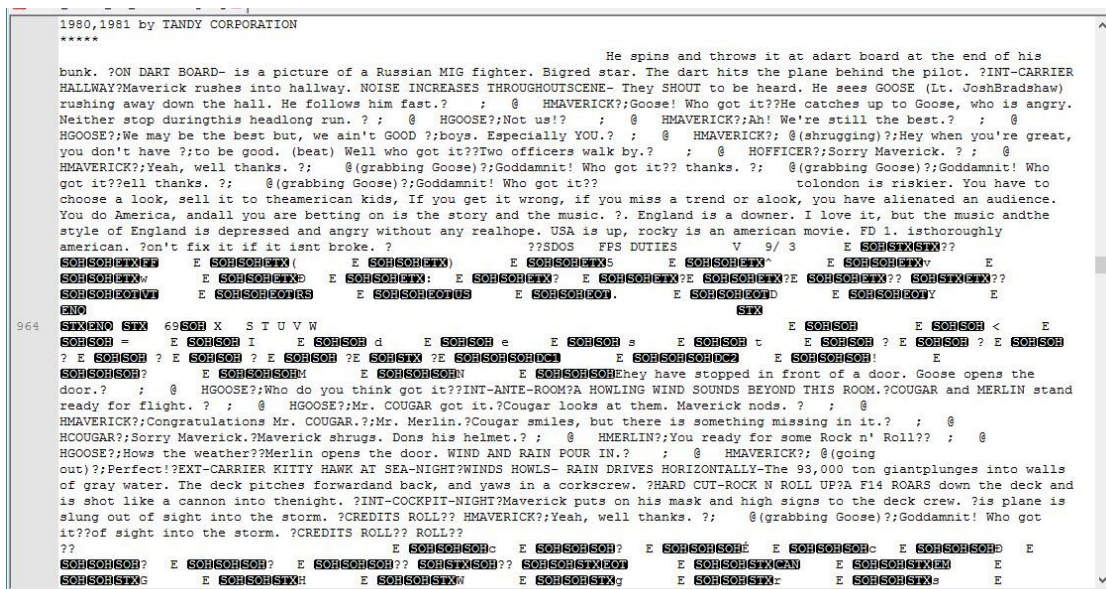

```
1980,1981 by TANDY CORPORATION
*****
                                He spins and throws it at adart board at the end of his
bunk. ?ON DART BOARD- is a picture of a Russian MIG fighter. Bigred star. The dart hits the plane behind the pilot. ?INT-CARRIER
HALLWAY?Maverick rushes into hallway. NOISE INCREASES THROUGHOUTSCENE- They SHOUT to be heard. He sees GOOSE (Lt. JoshBradshaw)
rushing away down the hall. He follows him fast. ? @ HMAVERICK?;Goose! Who got it??He catches up to Goose, who is angry.
Neither stop duringthis headlong run. ? ; @ HGOOSE?;Not us! ? ; @ HMAVERICK?;Ah! We're still the best. ? ; @
HGOOSE?;We may be the best but, we ain't GOOD ?;boys. Especially YOU. ? ; @ HMAVERICK?; @(shrugging)?;Hey when you're great,
you don't have ?;to be good. (beat) Well who got it??Two officers walk by. ? ; @ HOFFICER?;Sorry Maverick. ? ; @
HMAVERICK?;Yeah, well thanks. ? ; @(grabbing Goose)?;Goddamnit! Who got it?? thanks. ? ; @(grabbing Goose)?;Goddamnit! Who
got it??all thanks. ? ; @(grabbing Goose)?;Goddamnit! Who got it??
                                tolonond is riskier. You have to
choose a look, sell it to theamerican kids, If you get it wrong, if you miss a trend or alook, you have alienated an audience.
You do America, andall you are betting on is the story and the music. ? . England is a downer. I love it, but the music andthe
style of England is depressed and angry without any realhope. USA is up, rocky is an american movie. FD 1. 1sthoroughly
american. ?on't fix it if it isnt broke. ? ??SDOS FPS DUTIES V 9/ 3 E SXXXXXXXXXX??
XXXXXXXXXX E XXXXXXXXXXXX ( E XXXXXXXXXXXX) E XXXXXXXXXXXX5 E XXXXXXXXXXXX^ E XXXXXXXXXXXX, E
XXXXXXXXXX, E XXXXXXXXXXXX, E XXXXXXXXXXXX, E XXXXXXXXXXXX, E XXXXXXXXXXXX, E XXXXXXXXXXXX, E XXXXXXXXXXXX??
XXXXXXXXXX, E XXXXXXXXXXXX, E XXXXXXXXXXXX, E XXXXXXXXXXXX, E XXXXXXXXXXXX, E XXXXXXXXXXXX, E XXXXXXXXXXXX, E
XXXXXXXXXX, E XXXXXXXXXXXX, E XXXXXXXXXXXX, E XXXXXXXXXXXX, E XXXXXXXXXXXX, E XXXXXXXXXXXX, E
964 STWENO STX 69SOH X STUVW
SOHSH = E SOHSH I E SOHSH d E SOHSH e E SOHSH s E SOHSH t E SOHSH ? E SOHSH ? E SOHSH
? E SOHSH ? E SOHSH ? E SOHSH ?E SOHSH ?E SOHSHSOH001 E SOHSHSOH002 E SOHSHSOH! E
SOHSHSOH? E SOHSHSOH E SOHSHSOH E SOHSHSOH E SOHSHSOHThey have stopped in front of a door. Goose opens the
door. ? ; @ HGOOSE?;Who do you think got it??INT-ANTE-ROOM?A HOWLING WIND SOUNDS BEYOND THIS ROOM.?COUGAR and MERLIN stand
ready for flight. ? ; @ HGOOSE?;Mr. COUGAR got it.?Cougar looks at them. Maverick nods. ? ; @
HMAVERICK?;Congratulations Mr. COUGAR.?.Mr. Merlin.?Cougar smiles, but there is something missing in it. ? ; @
HCOUGAR?;Sorry Maverick.?Maverick shrugs. Dons his helmet. ? ; @ HMERLIN?;You ready for some Rock n' Roll?? ; @
HGOOSE?;How's the weather?Merlin opens the door. WIND AND RAIN POUR IN. ? ; @ HMAVERICK?; @(going
out) ?;Perfect!EXT-CARRIER KITTY HAWK AT SEA-NIGHT?WINDS HOWLS- RAIN DRIVES HORIZONTALLY-The 93,000 ton giantplunges into walls
of gray water. The deck pitches forwardand back, and yaws in a corkscrew. ?HARD CUT-ROCK N ROLL UP?A F14 ROARS down the deck and
is shot like a cannon into thenight. ?INT-COCKPIT-NIGHT?Maverick puts on his mask and high signs to the deck crew. ?is plane is
slung out of sight into the storm. ?CREDITS ROLL?? HMAVERICK?;Yeah, well thanks. ? ; @(grabbing Goose)?;Goddamnit! Who got
it??of sight into the storm. ?CREDITS ROLL?? ROLL??
??
SOHSH? E SOHSH? E SOHSH? E SOHSH? E SOHSH? E SOHSH? E SOHSH? E SOHSH? E SOHSH? E
SOHSH? E SOHSH? E SOHSH? E SOHSH? E SOHSH? E SOHSH? E SOHSH? E SOHSH? E
SOHSH? E SOHSH? E SOHSH? E SOHSH? E SOHSH? E SOHSH? E SOHSH? E SOHSH? E
```

Text editor view of one of the Skaaren floppies displaying ASCII and code of a screenplay draft of *Top Gun*, 1985

Special Collections, Archives & Preservation at the University of Colorado Boulder

Investigation of the resulting 12 disk images, resolved using the DEC RX01 image profile, indicated that the initial positive sector reads displayed from the KryoFlux interface were indeed accurate. To do this investigation we have used a hex editor to display the disk image contents. As mentioned earlier in the background for this collection, the content displayed by the hex editor tracks well with the labeling on the disks, revealing a National Endowment for the Arts report, numerous documents describing and cataloging previous work and equipment, along with programming instructions, some almost certainly in GRASS, for generating and manipulating vector graphics. These are promising results, but it is of course in the interest of the archives and future researchers to translate this data into discrete files for better use and inspection. While some study could be done in a hex editor view, files are not always linearly set out in the disk geometry, and all formatting is also unrepresented.

```
0A09 4D4F5609 23444653 495A2C44 424C5349 5A00A009 494E544D 4F560944 42554645 4E2C4449 52535450 000A0954 53544209 40244352 54464647
0A09 4C4E4853 45420924 50444543 000A0949 4E544D4F 56094452 342C5233 000A094C 4E485355 42092441 5343495A 000A094D 4F560944 46494645
094C 4E485355 42092450 44454300 000A944E 544D4F56 09445236 2C52330D 000A944E 48535542 09244153 43495A0D 0A095453 54420949 474E464C
000A 09424745 09434F4E 5858080A 094D4F56 09231310 322C4024 45572842 41534529 000A094C 4E484A4D 50092445 4D000A43 4F4E5F58 3A094245
4200 0A09494E 544D4F56 09425546 454E302C 44495253 5450000A 094D4F56 0923444B 53495A2C 44424C53 495A000A 44495233 423A094D 4F560924
4509 44495231 3700A009 42520943 4C4F4446 49000A44 49523137 3A094D4F 56095546 44424C4B 2C44424C 4F434E0D 0A094453 52094C52 2C47424C
5609 5546444C 53452C52 3000A009 4A4D5009 44495231 35000A44 4952373A 09414444 09233138 2E2C5230 000A0942 52094449 5233000D 0A47424C
5400 0A4D4449 52433031 09093B49 4620474E 452C2041 5353454D 424C4520 4D494E49 44495243 4F52450D 0A2E4946 4E5A204D 44495243 000A092E
4D49 4E494449 52434F52 000A2E45 4E444300 0A2E4946 5A204D44 4952430D 0A092E54 49544C45 09444952 434F5209 2A535741 5609494E 4720434F
3424 0909093B 40542753 20412043 4F505900 0A09444C 52205233 0909093B 434F554E 54454000 0A32424A 09414444 204C4E47 45540023 5232323C
4420 494E2043 4F54E55A 000A0942 49542023 42495438 2C403228 52322909 093B4558 54454054 533F000A 09424551 20324009 09093B4E 4F0D0A09
4543 544F5259 20434D44 2A000A2E 454E4443 000A2E4D 4143524F 20412053 54554646 000A2E41 5343495A 202A5354 5546462A 000A2E45 4E444D00
544C 09050529 4E54204E 45414620 4E414045 5320414E 44205349 5445530D 0A3B2043 4F4D4D41 4E442054 4F205052 494E5420 54484520 434F4E54
5232 292C5232 09093B4E 4558540D 0A094252 20322400 0A34243A 09494E54 4D4F5620 434D4553 532C5233 000A0942 5220524 0909093B 5052494E
5927 000A3324 3A094C4E 48535542 20245044 45430909 38505249 4E542054 4F54414C 20494E20 5233000A 09494E54 4D4F5620 564D4553 532C5233
4620 54484520 494E434F 52452044 49524543 544F5259 000A3B20 53544154 55523049 4E464F20 41424F55 54205448 45402041 4E442046 52454520
4154 41000A00 0A444952 434F523A 092E574F 52444946 49543132 2C4C2E53 5750000A 09434D50 42204024 53595546 4730284E 41534529 2C23274C
2056 4543544F 5253000A 35243A09 4C4E4853 55422024 41534149 5A000A09 42405120 23424954 31302C23 52312909 09093B50 55544C49 4227443F
2031 240D0A09 094E540D 4F562050 4C4D4553 532C5233 000A094C 4E485355 42202441 5343495A 000A3124 3A09504F 50205C52 303F000A 09525453
4C49 4E452050 52494554 45523F0D 0A09424E 45203224 000A0949 4E434220 40244C50 4F415343 28424153 45290909 3B545552 4E204C50 204F4E0D
5542 20245043 4C454152 000A3224 3A09434C 52094446 494C4553 000A0943 4C520944 544F5441 4C0D0A09 494E544D 4F560944 52392C52 3300A009
0A09 2E534254 544C0944 4F49542D 2D505249 4E542054 59504520 4F46204E 414D4544 20414C4C 4F434154 494F4E0D 0A0D0A44 4F49543A 09494E54
5054 41422C52 3000993B 53455455 5009464F 52204C4F 4F50000A 094D4F56 20322852 31292C52 32090909 3B474554 20545050 45204652 4F4D2057
0924 41534349 5A000A09 4558544D 4E546924 4E544E44 462C5352 300D0A44 49524231 3A09434D 50205352 302C244E 54444953 50284241 53452909
5945 543F000A 09424849 53204449 52434950 0909093B 59455300 0A094553 54204053 52300909 093B4953 20424E59 424F4E59 20544645 5245000A
5200 0A12123A 09434058 2052322C 28523029 2009093B 464F554E 44205459 59453F00 0A094245 51205052 494E5449 56090909 3B595550 000A0954
5928 0909093B 534E4950 20414444 52455353 202D4953 2045204F 20544142 4C453F0D 0A09424E 45203124 09090909 3B4E4F50 450D0A09 4A535220
4952 43314109 09093B59 45532C20 494E5445 52524F47 41544500 0A094144 44202331 302C5352 30090909 3B545259 204E4558 54204F4E 450D0A09
```

Hex editor view of one of the Vasulka "grass" floppies displaying programming code

There is a number of emulation programs that can accommodate the DEC RX01 and RX02 floppy disk drives. Two of particular interest are the *SimH*, or History Simulator software [17], a freeware emulator of multiple early computer systems from DEC's run of PDP machines to early Hewlett Packard and IBM systems. Also of note is the *Ersatz-11* emulator [18], dedicated to emulating the PDP-11, from the D Bit developer. Because DEC RX01/02 drives were used in both PDP-8 and PDP-11 systems, it is uncertain which PDP system would be best to emulate. Further, these system did not necessarily need to run an operating system for operation, or could be booted with a number of potential operating systems, from OS 8 to early iterations of the Unix. This further complicates successful interaction with the disk image, as the archivist has less clarity on what operating systems or software frameworks would likely have been used. Up to this point, CU Boulder has not been able to create an emulation environment in either *SimH* or *Ersatz-11* that facilitates access at the file level or otherwise to the disk images. Further research and experimentation is needed.

Austin Roche collection of Datapoint records

A preliminary exploration of raw streaming data was recorded from the KryoFlux controller. As expected, these streams do not resolve to any image profile within the KryoFlux default suite, so the streams await

further analysis. It is known that the format used by Datapoint to support the Datapoint 1800 personal computer has some similarity to the format used by DEC to support the RX02 disk drive system, and this will be investigated, likely through a comparative analysis. A box of new and formatted for Datapoint diskettes was discovered recently as well, opening new investigation possibilities for writing formatted disks to support sector level disk duplication.

CONCLUSION

We have presented three cases of 8-inch floppy disk collections: two from cultural heritage institutions and a third from an independent collector. In all instances, it is apparent that vital, historical information is present on the media. For both the Harry Ransom Center and CU Boulder collections, creative professionals made extensive use of the then-nascent personal computer to produce documents and data. In the independent Datapoint collection, the format and systems themselves are the subject of interest as a point in computing history.

There are commonalities in the data acquisition methods across our cases to suggest some optimism for others facing a similar media challenge. In all cases, use of the KryoFlux floppy controller was essential. This device's ability to sample the magnetic fluxes on the disk platters constitutes the first real data transfer, from which subsequent investigations are based. Moreover, the device's relative versatility and agnosticism as to on-device formatting allows connection to at least some 8-inch drive models. Following this, the D Bit adapter and converter are promising solutions which, in conjunction with the KryoFlux, allow full connection of an 8-inch drive to a modern host computer. For CU Boulder and the Harry Ransom Center, for which the disk content forms the primary interest, a hex editor proved a powerful tool for both the confirmation of a valid disk image interpretation and to gain insight into the specific content itself.

Nevertheless, differing steps also indicate much further work. Drive selection can be difficult, since it is not possible to ascertain if a drive is calibrated correctly, if a sensor is fully operational, or if other malfunctions are present. While we have not seen drives over a few hundred dollars, it is not a trivial purchase, and one that comes with some risk. Following this, knowledge or expertise in the mechanical operation of a floppy disk drive is very valuable should a drive not function, or if one needs to establish a 'baseline' to understand where a data reading problem is occurring. Even in the case of considerable expertise, the landscape of technical functions in early personal computer systems can prove extremely difficult to decode and repeat, as demonstrated in the Datapoint 1800 collection.

Some practitioners may have the good fortune of the raw stream data resolving into a known image profile through KryoFlux's disk imaging tool, as in CU Boulder's case, but others may not, and may have to rely on other software here (e.g. the *HxC* program), or experiment with the customizable KryoFlux image profiles. The KryoFlux and D Bit setups described here are promising arrangements, but each of these devices come from independent vendors. Even if this were not so, it would nevertheless be wise to diversify solutions. If others can describe setups that utilize other hardware, including the original machines that operated these drives, this will broaden options for data recovery. Finally, the emulation of machines such as the PDP-8, PDP-11 and TRS-80, has a higher learning curve than other emulation

software for more recent hardware and operating systems. Even when the machine is known, configurations for these systems are wider in possibility, or at least less clear, than more modern or later systems. Much more knowledge and guidance on the emulation of these very early personal computers needs to spread to the cultural heritage communities.

ACKNOWLEDGMENTS

The authors would like to the Kryoflux, SimH, and TRS-80 retrocomputing communities for their guidance. Walker Sampson would like to thank the Vasulkas for their donations and continued interest and generosity in this research. Abby Adams would like to thank Dr. Patricia Galloway connecting her with Austin Roche and Adams' student assistant, Virginia Dempsey, for all her hard work on the project. Adams would also like to thank the Skaaren family for their donation and support.

REFERENCES

- [1] Denise de Vries. 2016. 8" Disk Recovery: Kryoflux and Catweasel. Open Preservation Foundation. Retrieved June 14, 2018 from <http://openpreservation.org/blog/2016/09/14/8-disk-recovery-kryoflux-and-catweasel/>.
- [2] Dan Sandin. 2013. GRaphics Symbiosis System - GRASS. electronic visualization laboratory. Retrieved June 14, 2018 from <https://www.evl.uic.edu/dan/GRASS.html>
- [3] Katherine Mosley. 1995. Warren Skaaren: An Inventory of His Papers at the Harry Ransom Center. Harry Ransom Center. Retrieved June 14, 2018 from <http://norman.hrc.utexas.edu/fasearch/findingAid.cfm?eadid=00123>.
- [4] Alison Macor. 2017. *Rewrite Man: The Life and Career of Screenwriter Warren Skaaren*. University of Texas Press, Austin, TX.
- [5] Steven Stengel. 2016. Tandy/Radio Shack TRS-80 model II computer. Steve's Computer Collection. Retrieved June 14, 2018 from <http://oldcomputers.net/trs80ii.html>.
- [6] Reed, Matthew. 2018. Scripsit. TRS-80.org. Retrieved June 14, 2018 from <http://www.trs-80.org/scripsit/>.
- [7] Computer History Museum. 2018. Datapoint catalog records. Catalog Search | Computer History Museum. Retrieved June 14, 2018 from <http://www.computerhistory.org/collections/search/?s=datapoint+1800>.
- [8] D Bit. 2018. FDDC floppy disk power converter. D Bitz Ersatz-11 PDP-11 emulator. Retrieved June 14, 2018 from <http://www.dbit.com/fddc.html>.

[9] D Bit. 2018. FDADAP floppy disk adapter. D Bitz Ersatz-11 PDP-11 emulator. Retrieved June 14, 2018 from <http://www.dbit.com/fdadap.html>.

[10] Y-E Data. 1985. *Product Specifications - Double Sided, Half Height 8 Inch Floppy Disk Drive - YD-180-1601*. ClassicCmp. Retrieved June 14, 2018 from http://www.classiccmp.org/hp/ye%20data/YD180_~1.PDF.

[11] KryoFlux Products & Services Ltd.. 2017. Technical Overview. KryoFlux Products & Services Ltd. Retrieved June 14, 2018 from https://www.kryoflux.com/?page=kf_tech.

[12] Shugart. 1977. *SA850/851 Bi-Compliant Double Sides Diskette Storage Drive OEM Manual*. Shugart, Sunnyvale, CA. Retrieved June 14, 2018 from http://bitsavers.informatik.uni-stuttgart.de/pdf/shugart/SA8xx/39017-0_SA850_851_OEM_Manual_Nov80.pdf.

[13] HxC2001. 2013. HxC Floppy Emulator - Step by Step Guide. HxC2001. Retrieved June 14, 2018 from http://hxc2001.com/download/floppy_drive_emulator/HxC_Floppy_Emulator_Software_User_Manual_ENG.pdf

[14] Matthew Reed. 2018. The TRS-80 Model II. TRS-80.org. Retrieved June 14, 2018 from <http://www.trs-80.org/model-2/>.

[15] Ember, Gregory. 2017. Home of the MAME Project. Retrieved June 14, 2018 from <http://mamedev.org/>.

[16] University of Freiburg. 2018. Emulation as a Service -- bwFLA. Retrieved June 14, 2018 from <http://eaas.uni-freiburg.de>.

[17] Supnik, Bob. 2018. Computer Simulation and History. Retrieved June 14, 2018 from <http://simh.trailing-edge.com/>.

[18] D Bit. 2018. D Bitz Ersatz-11 PDP-11 emulator. Retrieved June 14, 2018 from <http://www.dbit.com/>.