

Using micropipettes

Anatomy of a pipette

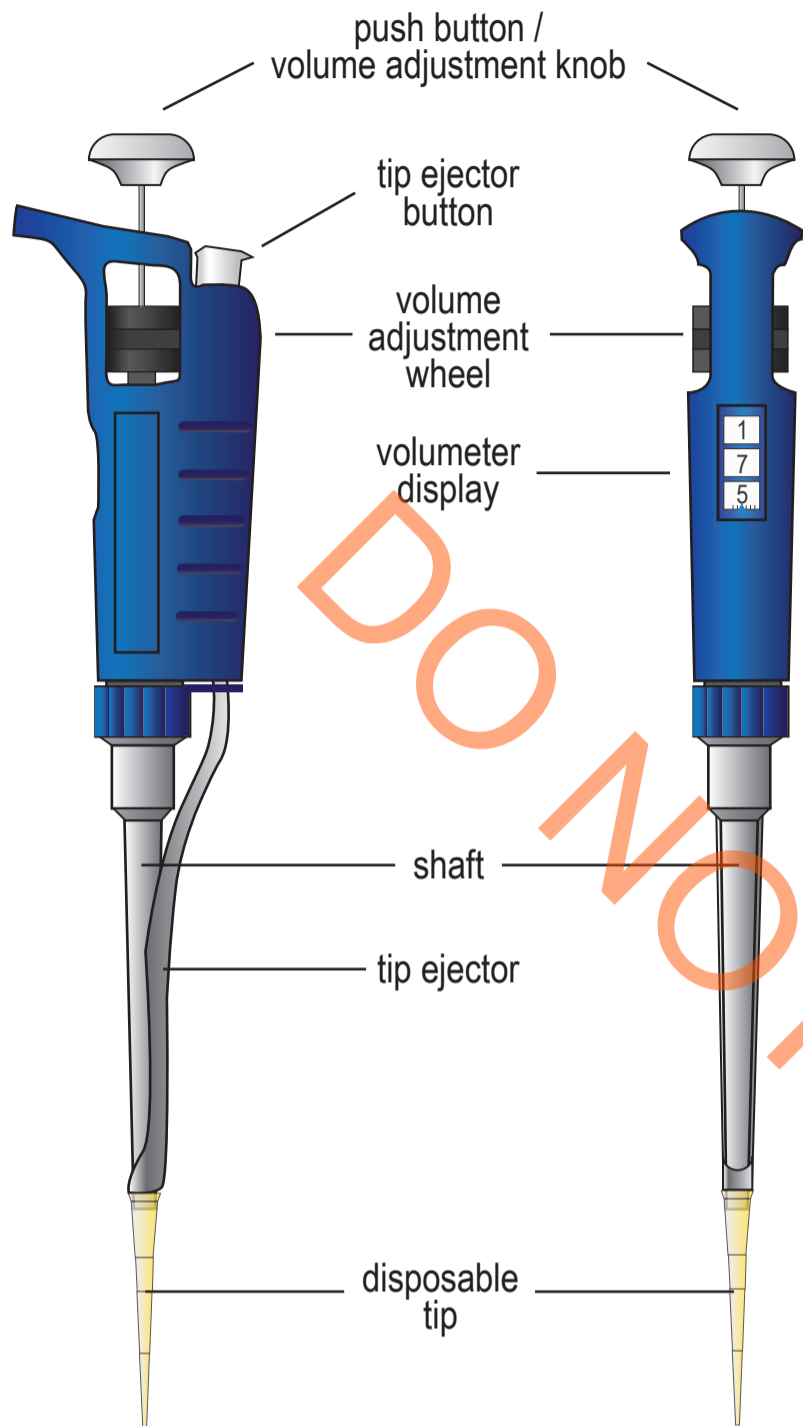

Air displacement principle

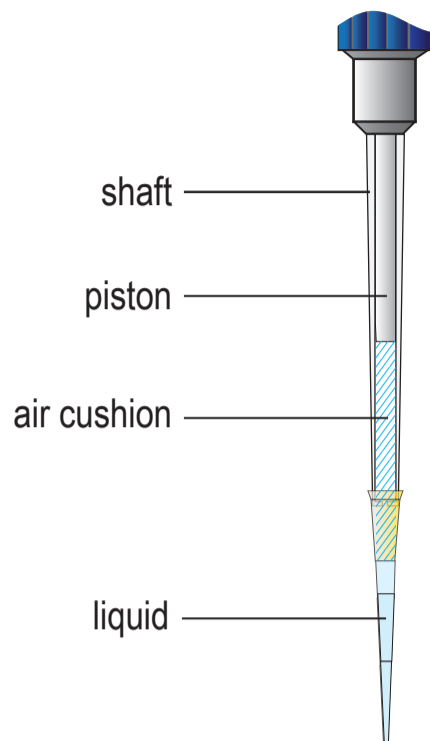

- 1 Set volume
- 2 Expel air
- 3 Aspirate
- 4 Dispense

Setting volume

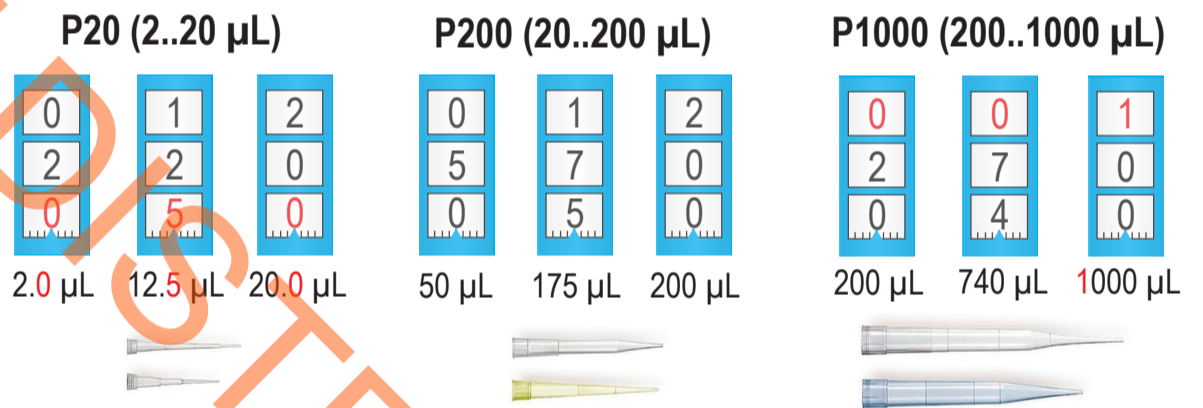

Forward pipetting

(most aqueous solutions and buffers)

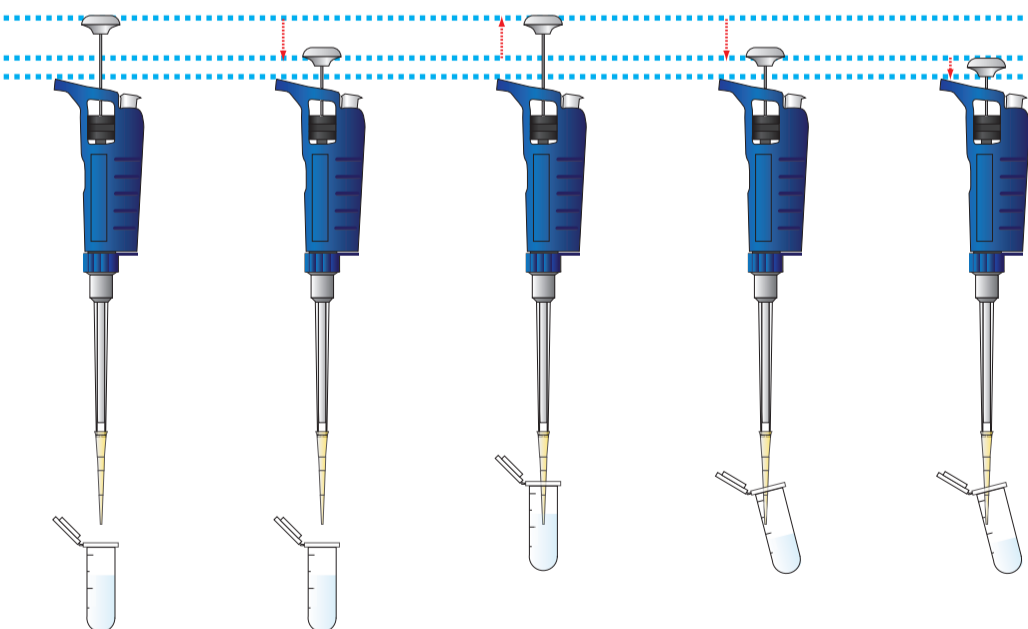

Reverse pipetting

(viscous, foaming or volatile liquids)

